



**Product Catalogue 2016**



# One life... see it!

Welcome to the Masai® line catalogue.

With 3 generations of automotive engineering experience, we've created a range of products to style and enhance any Land Rover Defender. Here at Masai, we believe our products are a perfect example of how simple ideas lead to products that look good and perform great.

## Make it your own

The Land Rover Defender is an icon in British automotive history and is one of the most flexible off-road vehicles ever built. Masai has an extensive and growing range of products to enhance your Defender. From panoramic glass windows to rugged utilitarian bumpers, roof racks, light bars and LED lighting. **You're sure to find the perfect product for your Land Rover Defender.**

## A name you can trust

# Contents

	Page		Page		Page
Panoramic fixed side windows	5	Heated front windscreen	13	Steering & differential guards	34
Panoramic sliding side windows	5	Interior lighting & storage	14	LED & HID work & driving lights	37 - 47
Panoramic rear quarter lights	5	Window trim kits	15	LED light bars	48 - 50
Zeppelin fixed side windows	6	Seat covers	16	Roof light bars	50
Zeppelin sliding side windows	6	Wing mirrors	17	LED brake, indicator & side lights	51
Zeppelin quarter lights	6	Spare wheel carriers	19	Front & rear lamp guards	52 - 53
Front door glass	7	Bonnets	20	Rear window brake light	54
Second row door glass	7	Chequer plate accessories	21	LED licence plate light	54
Fixed side windows	7 - 8	Nas style & rear steps	22	Window catches & clips	54
Sliding side windows	8	Side steps	23	LED & HID work lamps	55 - 56
Double sliding side windows	8	Tree / rock sliders	24	Aluminium shovel	57
Quarter lights	9	Fire & ice style side steps	24	Shock absorber mounts	57
Heated rear door glass	9	Roof access ladders	25	Bulkhead outrigger	57
Window guards	9	Luggage & flat roof racks	26 - 29	30mm wheel spacers	58
Fixed blind spot windows	10	Winch bumpers	30	Window cut-out templates	58
Sliding blind spot windows	10	LED & light bar bumpers, A-bar	31	Window rubber seals	58

# Windows and Interior Styling



*Our signature Panoramic windows - a Masai original design*

# Panoramic Windows



Masai bonded, tinted panoramic windows for 90 and 110

Stylish. Minimalist. Durable. Whether you are looking to update your old Landy glass or convert your panel van workhorse into a family vehicle. Our striking and exclusively designed panoramic windows are an easy choice. Available in sliding window or fixed configuration.

- 70% no light transmission factory tint, not a stick-on film
- High quality fleck runners
- 4mm 43R toughened safety glass

Application	SKU Fixed	SKU Sliding
90	PANORAMICS-90F	PANORAMICS-90S
110	PANORAMICS-110F	PANORAMICS-110S



Masai bonded, tinted panoramic quarter lights for 90 and 110

Installed along with the Masai bonded, tinted panoramic windows or as a standalone accessory, our panoramic quarter lights are guaranteed to dramatically enhance the look of your Defender. Available in standard version which leaves a 1cm gap around the glass edge and bodywork or maxi version which takes the glass to the edge of the vehicle.

- 70% no light transmission factory tint, not a stick-on film
- 4mm 43R toughened safety glass
- Offers greater security than standard quarter light windows
- DIY installation or fitting service is available

Application 90 & 110	SKU
Standard	PANORAMIC/QTR
Maxi	PANORAMIC/QTR-MAXI



Masai bonded, tinted panoramic windows for 110 hard top

Designed for 110 hard top vehicles. Our bonded, tinted 110 hard top panoramic windows feature a 70% no light transmission factory tint and fixed or lockable slide-opening version.

- 70% no light transmission factory tint, not a stick-on film
- High-quality fleck runners
- 4mm 43R toughened safety glass
- DIY installation or fitting service is available

Application 110	SKU
Hard top slide opening	FL-PAN110-2PG-1SLW
Hard top fixed	FL-PAN110-2PG-1FW

# Zeppelin Windows



Masai tinted Zeppelin windows for 90 and 110  
Our hallmark panoramic glass, redesigned.

Masai Zeppelin - our new style bonded, tinted panoramic windows for the Defender 90 and 110. Sold as a pair, these beautiful windows are lockable and slide-opening, featuring a premium factory privacy tint.

- 70% no light transmission factory tint, not a stick-on film
- High quality fleck runners
- 4mm 43R toughened safety glass

Application	SKU
90, 110	MZEPP-S



Masai Zeppelin Quarter Lights for 90 and 110

Rear Tinted Bonded Quarter Lights to match our Zeppelin Tinted Windows, manufactured to the same specification.

Application	SKU
90, 110	MZEPP-QTR

Masai fixed tinted Zeppelin windows for 90 and 110

Masai Zeppelin - bonded, tinted panoramic windows for the Defender 90 and 110. Sold as a pair, these beautiful windows feature a premium factory privacy tint and polished, rounded corners.

- 70% no light transmission factory tint, not a stick-on film
- High quality fleck runners
- 4mm 43R toughened safety glass

Application	SKU
90, 110	MZEPP-F

## Our Trademark Windows

We design our range of tinted windows to enhance the look of your Defender. We manufacture them using premium quality materials. We prepare our windows with a 70% no light transmission factory tint, not a stick-on film. Using our E43R toughened safety glass coupled with high quality fleck runners. Our windows are guaranteed to be silent, rigid, leak proof and draft free.

# Side and Rear Windows



Tinted front door windows for 90, 110 and 130

**The perfect finishing touch for a set of Masai's Tinted, Panoramic or Zeppelin windows.**

Our branded front door glass features a factory 15% galaxy grey tint.

- 15% no light transmission factory tint, not a stick-on film
- Polished edges
- 4mm 43R toughened safety glass
- DIY installation or fitting service is available

Application	SKU
90, 110 & 130	ALR4774 - ALR4772



Dark tinted second row door glass for 110 and 130

Our dark tinted rear side door windows are manufactured to the same high quality that you will find throughout our product range.

This kit comes with LH (left side) glass and RH (right side) glass and rear quarter components - 4 parts in total.

- 70% no light transmission factory tint, not a stick-on film
- 4mm 43R toughened safety glass
- Powder coated aluminium frame
- Standard size replacement
- DIY installation or fitting service is available

Application	SKU
110 & 130	LR-SDG



Fixed side windows for TD5, 200Tdi, 300Tdi -90 and 110

Tired of draughts, rattles and leaks? Our high quality side windows are guaranteed to fix all of these issues and more. These fixed windows are a standard size replacement. Available clear, green tint or 70% no light transmission factory dark tint.

Suitable for TD5, 300 Tdi and 200 Tdi internal trims.

- 4mm 43R toughened safety glass
- DIY installation or fitting service is available

Application 90 & 110	SKU
Fixed Dark tint	SFW5050DT
Fixed Green tint	SFW5050GT
Fixed Clear	SFW5050CLR



Sliding and double sliding side windows for TD5, 300Tdi, 200Tdi - 90 and 110

We manufacture a high quality replacement side windows to fit both the Defender 90 and 110. Using unique design aluminium profile which is rattle and leak proof. These factory tinted windows are available in sliding or double sliding configurations. Double sliding shown above. Suitable for TD5, 300 Tdi and 200 Tdi internal trims.

- Dark tint is a 70% no light transmission factory tint, not a stick-on film
- High quality fleck runners
- 4mm 43R toughened safety glass

Application 90 & 110	SKU
Sliding dark tint	SSW5050DT
Sliding green tint	SSW5050GT
Sliding clear	SSW5050CLR
Double sliding dark tint	SDSW5050DT
Double sliding green tint	SDSW5050GT
Double sliding clear	SDSW5050CLR



Fixed side windows for TDCi Puma

Tired of draughts, rattles and leaks? Our high quality side windows are guaranteed to fix all of these issues and more. These fixed windows are a standard size replacement. Available clear, green tint or factory dark tint. Suitable for TDCi Puma internal trims.

- 4mm 43R toughened safety glass
- Dark tint is a 70% no light transmission factory tint, not a stick-on film
- DIY installation or fitting service is available

Application 90 & 110	SKU
Fixed dark tint	SFW5070DT
Fixed green tint	SFW5070GT
Fixed clear	SFW5070CLR



Sliding and double sliding windows for TDCi Puma

We manufacture a high quality replacement side sliding windows or double sliding windows to fit both the Puma and TDCi. Using unique design aluminium profile which is rattle and leak proof. These windows have a 70mm lower radius and a 50mm top radius to fit the unique internal trim on new style TDCi Puma Defenders.

- Dark tint is a 70% no light transmission factory tint, not a stick-on film
- Available in sliding and double sliding configurations
- High quality fleck runners with 4mm 43R toughened safety glass

Application 90 & 110	SKU
Sliding dark tint	SSW5070DT
Sliding green tint	SSW5070GT
Sliding clear	SSW5070CLR
Double sliding dark tint	SDSW5070DT
Double sliding green tint	SDSW5070GT
Double sliding clear	SDSW5070CLR



# Rear Windows and Window Guards



Dark tinted rear quarter lights for 90 and 110

Our premium tinted quarter lights are designed to reduce light glare and reflect heat. These windows have been designed as standard size replacements for the Defender 90 and 110, but may fit other models.

- 70% no light transmission factory tint, not a stick-on film
- 4mm 43R toughened safety glass
- Standard size replacement
- DIY installation or fitting service available

Application 90 & 110	SKU
Pair of quarter lights	LRD-DTRQLW
Pair of rubber seals for quarter lights	DEF-ROL-WS



Masai tinted heated rear door glass for 90 and 110

Our tinted heated rear door glass features a heat reflective, glare reducing, coating over a premium factory tint, ideal for expeditions in sunny climates.

- 70% no light transmission factory tint, not a stick-on film. Standard size replacement
- 4mm 43R toughened safety glass. DIY installation or fitting service available
- Please note post 2002 rear door glass is fitted with a rubber seal as shown top left image. Pre 2002 has no rubber seal as shown on image above
- High level brake lights can be fitted to both

Year	SKU
Pre 2002	LRD-RDG-PRE2002
Post 2002	LRD-RDG-POST2002
Post 2002 Rear door glass seal	MASAI-CVW500010



Side window guards

- Will fit all defenders with factory fitted windows
- Sold as a pair
- Precision laser-cut steel
- Zinc plated and powder coated in black
- Includes rivets
- DIY installation or fitting service available

Application	SKU
County side window	M-SWG01

# Blind Spot Windows



## Masai slide opening tinted blind spot windows for 90 and 110

Our tinted blind Spot windows are designed for panel van Defenders to provide the driver with extra visibility where it counts. They will also fit most flat sided vans or trucks.

These windows are guaranteed to be both leak and draft proof. They feature a heat reflective and glare reducing tint.

- 70% no light transmission factory tint, not a stick-on film
- 4mm 43R toughened safety glass
- DIY installation - full fitting kit provided

Application	SKU
90, 110	SO-BSW



## Masai fixed tinted blind spot windows for 90 and 110

Our tinted blind Spot windows remove blind spots and provide extra visibility and light to panel van Defenders without compromising security. They will also fit most flat sided vans or trucks. Unlike our slide opening blind spot windows, these windows have no external frame, only polished edges. Sold as a pair or double sided pair.

- 70% no light transmission factory tint, not a stick-on film
- 4mm 43R toughened safety glass
- DIY installation - sealant can be provided
- Fitting service available

Application 90 & 110	SKU
Pair, 2 windows	LRD-BSW
Pair double side, 4 windows	LRD-DBSW



# Camper Style Windows



## Masai dark tinted camper style side windows for retrofit and hard top conversion

Our camper style windows suit a variety of uses where increased access, light and ventilation is desired but not at the expense of security.

Above image is our "standard size" side window 1107mm x 477mm which can be retrofitted to all Defender window apertures including 50:50 radius corners on 200Tdi/300Tdi/TD5 and 50:70 radius on TDCi Puma. It is suitable for use with factory fitted internal trims. Use as direct replacement or when converting a hard top.

We also have sizes 810mm x 477mm which is ideal for the 110 and 963mm x 419mm for the crew cab / pick-up rear window.

Although originally designed for use on Land Rover's, our windows fit many other vehicles and serve a number of different purposes from truck sleeping pods to narrow boat deck hatches.

- Includes two gas struts for smooth opening and closing. Struts can be removed to allow full opening
- Three handle locking with keys. Window opening is maximum 200mm from cab body
- Size 1107mm x 477mm, the cut-out aperture is 1057mm x 427mm - Standard size, see left image
- Size 963mm x 419mm, the cut-out aperture is 913mm x 369mm - Crew cab window, see above image
- Size 810mm x 477mm, the cut-out aperture is 760mm x 427mm - Ideal for 110, see middle image
- The Radius of the cut out aperture needs to be 76mm.
- Black powder coated aluminium frame
- Includes rubber seal and internal bezel
- 43R 4mm toughened safety glass
- 70% no light transmission dark tint
- Factory prepared tint, not a stuck on film
- Sold as single windows

Application 90 & 110	SKU
Standard	DEF1107X477

Application 90 & 110	SKU
Small	DEF810X477

Application	SKU
Defender crew cab	DEF963X419

# Sunroofs and Shooting Hatch / Vent

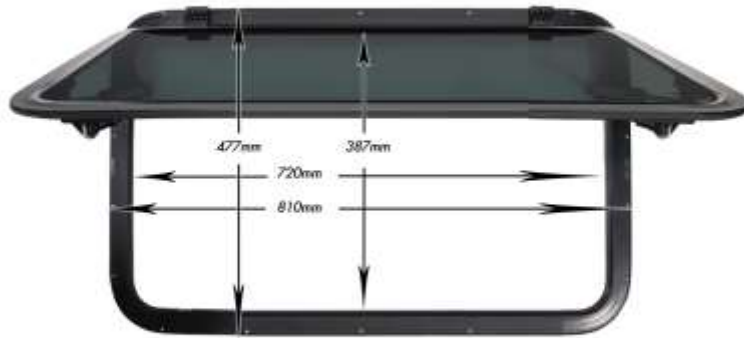

Size shown is 810mm x 477mm

This Sun Roof has a variety of uses where increased access, light and ventilation is needed but not at the expense of security. Includes Internal Bezel Trim (aluminium L section 20mm x 20mm, black powder coat paint). This bezel can be used as a template to cut out the aperture. If you need the Sun Roof completely wide open the gas strut brackets can be

## Sunroofs

Size	SKU
810 X 477mm	DEF810X477-SR
1107 X 477mm	DEF1107X477-SR
963 x 419mm	DEF963X419-SR

- Includes rubber seal and internal bezel
- 43R 4mm toughened safety glass
- 70% no light transmission dark tint
- Factory prepared tint, not a stuck on film



## Wide opening vent / shooting hatch

If you need increased light, ventilation and accessibility, but not at the cost of security, **install Masai's wide opening vent/shooting hatch.**

- 4mm 43R toughened safety glass
- 70% no light transmission dark tint to reduce glare
- Dual handle locking with keys
- Includes rubber seal and internal bezel
- Will fit anything with a flat surface
- Measures 810mm x 600mm externally
- Designed to fit in-roof. Does not have drain holes for vertical installation on side panels

Application	SKU
All	DEF810X600

# Heated Windscreen and Opening Vent / Hatch



## Masai Defender heated windscreen

- Standard size replacement
- Heated glass
- Manufactured to original Land Rover quality
- DIY installation or fitting service is available
- Leak, draft and rattle free
- Fits all models from 1985 onwards
- 43R toughened safety glass
- Please visit our website to buy our heated windscreen wiring harness

Application Defender 1985+	SKU
Windscreen glass	M-LR042760
Windscreen rubber seal	MASAI-MTC5753



## Roof hatch / vent / sunroof

Roof hatch / vent designed for 4x4, horse boxes, mobile exhibition trailer, campervan, motor home, coach, lorry, bus or any vehicle, porta-cabin, enclosure etc. where increased light and ventilation is needed but not at the expense of security. Horsebox roof hatch / vent, trailer roof hatch, coach roof hatch light window, motor home roof light.

- Black powder coated aluminium frame
- Screen printed with dot fading reduces glare
- 43R 4mm toughened safety glass
- Moulded handles
- Weather sealed design

Size	SKU
530 X 530mm	RH530X530
970 X 530mm	RH970X530

# Interior Lighting and Storage



## Interior LED strip lights

Enhance and brighten the interior of your vehicle with low power consumption LED strip lights.

These lights are water, dust and shock resistant with an on/off switch. Our lights can be used in any vehicle or building. The 400mm is designed to fit on the rear door of a Defender County or panel van.

Available in three sizes:

- 245mm 12v or 24v, 300 lumens with 9 LEDs
- 400mm 12v or 24v, 600 lumens with 18 LEDs
- 555mm 12v or 24v, 900 lumens with 27 LEDs

Length	SKU
245	INT-LED-STRIP-245
400	INT-LED-STRIP-400-RD
555	INT-LED-STRIP-555



## Sporting box/rear storage drawers

Our custom made lockable storage units fit between the wheel arches on the load bed and enables you to neatly store, protect and lock away items in your vehicle. Draw dividers are an optional extra.

Available in various finishes:

- 001 = Light Silver
- 002 = Dark Grey
- 003 = Matt Black
- 004 = Gloss Black Walnut
- 005 = Gloss Walnut

Application	SKU
Pre 2007 220mm x 890mm x 1012mm	DEF220
Post 2007 185mm x 890mm x 1012mm	DEF185

Available in two heights; 220mm to sit flush with internal wheel arch tops on pre 2007 Defenders and 185mm to sit flush with Puma stepped internal arch. 220mm fits TDCi Puma too but is not flush.

# Interior Window Trim Kits



Internal window trim kit for Land Rover Defender 90

Spruce up the interior of your Defender 90 — 200/300/Td5 or TDCi Puma by fitting an internal window trim kit. Including rear side window and quarter light trims - 4 pieces in total - **Masai's** internal window trim kit covers the bare metal surrounding the rear side windows and quarter lights. These kits are supplied in a dark grey or black finish to suit most Land Rover interiors but can easily be painted to your requirements. Add a bespoke twist to a utilitarian classic.

- Left and right side rear side window and quarter light internal trims; 4 piece kit.
- High-quality GRP
- DIY installation or fitting service available
- Ideal for replacing worn trim kits or converting a panel-van into a County spec'
- Trim kit 1 is equivalent to Land Rover part numbers:  
MWC5832LOY, MWC8910LNP, ENV500170LOY, MWC8911LNP  
Fits all 200/300/Td5 Land Rover Defender 90s from 1987 to 2007 excluding TDCi Puma
- Trim kit 2 is equivalent to Land Rover part numbers:  
EQT500480LOY, EQT500490LOY, EQT500620LOY, EQT500630LOY  
Fits TDCi/Puma windows with forward facing seats and 70mm lower window radius



Application 90	Item Number
1987-2007	IWT-90TD5-BLK
1987-2007 Grey Trim kit 1	IWT-90TD5-GREY
TDCi Puma 2007+	IWT-90PUMA-BLK
TDCi Puma 2007+	IWT-90PUMA-GREY

Adjacent image shows TDCi Puma trims

# Seat Covers

## Replacement front and middle seat covers

Our replacement front seat covers, sold in pairs, will give new life to the interior of your Land Rover Defender. Designed to fit all models from 1989 to 2007, our premium leatherette seat covers include rear pockets, headrest covers and a foam lining. These seat covers are available in three different designs:

- Black with white stitching
- Black with orange stitching
- Grey with white stitching

We also provide an optional middle seat cover, available in:

- Black with white stitching
- Black with orange stitching
- Grey with white stitching



Design	SKU
Black with white stitching. Front seat cover	DF8907FR-BW
Grey with white stitching. Front seat cover	DF8907FR-GW
Black with orange stitching. Front seat cover	DF8907FR-BO
Black with white stitching. Middle seat cover	DF8907MID-BW
Grey with white stitch. Middle seat cover	DF8907MID-GW
Black with orange stitch. Middle seat cover	DF8907MID-BO





# Wing Mirrors



Long arm, standard or heated Defender wing mirrors for 90 and 110

- Standard sized head
- Fully homologated to EU standards
- Excellent for towing as well as general use
- Vibration tested
- Sold as a pair
- Black powder coated aluminium arms
- Salt spray tested
- 30cm arm length
- Heated or standard

Application 90 & 110	SKU
Standard	MTC5217-LA-NH
Heated	MTC5217-LA-H



Large head, standard arm or long arm wing mirrors for 90 and 110

- Large head for increased visibility - 270mm x 160mm
- Excellent for towing as well as general use
- Fully homologated to EU standards
- Vibration tested
- Sold as a pair
- Black powder coated aluminium arms
- Salt spray tested
- 18cm or 30cm arm length

Application 90 & 110	SKU
18cm arm length	OM1752
30cm arm length	OM1752-B



Standard or Heated Defender Wing Mirrors for 90 and 110

- Standard sized head
- Fully homologated to EU standards
- Replacement Land Rover part number MTC5217
- Vibration tested
- Sold as a pair
- Black powder coated aluminium arms
- Salt spray tested
- 18cm arm length

Application 90 & 110	SKU
Standard	MTC5217-NH
Heated	MTC5217-H

# Exterior, Utility and Off-Road Accessories



# Spare Wheel Carriers



Large chassis mounted spare wheel carrier for 90 and 110

Our heavy duty spare wheel carrier fixes to the chassis to minimise rear door hinge strain. Other benefits include an offset position to maximise access to the rear door, as well as increasing rearward viewing.

- High-strength steel construction
- Zinc galvanised
- Black powder coated paint finish
- DIY installation or fitting service is available
- For Pre 2002 versions you can purchase an optional Strengthening kit. Please contact us for details
- Extra heavy duty also available

Application 90 & 110	SKU
Heavy Duty	KTB500040-MASAI
Extra Heavy Duty	KTB500040-X-MASAI



Square section swing away spare wheel carrier for soft top or pick-up

The Masai swing-away spare wheel carrier is built to the same high standards as our large spare wheel carrier.

- High-strength steel construction, laser-cut for superior clean welding
- High quality zinc plating and black powder coated finish
- Robust locking catch mechanism to allow swing function
- Complete with fitting kit

Application	SKU
Defender Soft top or pickup	OM132B



Tubular, swing-away spare wheel carrier for soft top or pick-up

The Masai tubular swing-away spare wheel carrier is built to the same high standards as our large spare wheel carrier.

- High-strength steel construction, laser-cut for superior clean welding
- High quality zinc plating and black powder coated finish
- Robust locking catch mechanism to allow swing function
- Complete with fitting kit

Application	SKU
Defender Soft top or pickup	OM132B-RT

# Standard and GRP Bonnets, Sport Bonnet and Scoop



Puma style bonnet for Land Rover Defender - GRP

Our aftermarket version Land Rover Defender Puma Bonnet is made of GRP – Glass Reinforced Plastic. It is durable and flexible for heavy use. Lightweight compared to original steel Defender **bonnets, the GRP's net weight is just 10KG.** Standard or reinforced to add additional durability. Also fits TD5, TDCi Puma, 200/300 Tdi

We can also supply these fittings as extra:

- Hinge Kit (genuine Land Rover parts)
- Bonnet Decal Kit (genuine Land Rover parts)

Application 90 & 110	SKU
Single skin	GRP-PUMA-BON-S
Double skin	GRP-PUMA-BON-R



Genuine Steel Puma Bonnet for Land Rover Defender

A stylish, humped bonnet to enhance the look of any Land Rover Defender.

Genuine Land Rover Part - number BKA710140

We can also supply these fittings as extras:

- Hinge Kit (genuine Land Rover parts)
- Bonnet Decal Kit (genuine Land Rover parts)
- Striker and Hook Kit (not genuine Land Rover parts)

Application 90 & 110	SKU
Puma bonnet	MASAI-BKA710140

Application 90 & 110	SKU
Hinge kit	00042
Striker & hook kit	SHK-PB-LRD-763-MAS
Decal kit Land Rover	DAB500290/300



Masai Sport GRP Scooped Bonnet or TD5 GRP Bonnet Scoop Only

- Sport bonnet fits Puma TDCi, TD5, 200/300Tdi

Application 90 & 110	SKU
Masai sport scooped bonnet	GRP-DEF-SPORT-BON-01
Bonnet scoop	GRP-TD5-SCOOP-01

# Chequer Plate



Side sill protectors for 90 and 110

3mm thick high quality 5 bar pattern aluminium chequer plate side sill protectors for Land Rover Defender 90 and 110.

- Sold in pairs - Nearside and Offside
- Black powder coated or anodized silver finish
- Includes fittings kit
- DIY or fitting service is available

Application	SKU Black	SKU Anodised
90 Hard Top	SSP-90-BLK	SSP-90-SIL
110 Hard Top 2 Door	SSP-110-HT2D-BLK	SSP-110-HT2D-SIL
110 Station Wagon 4 Door	SSP-110-SW4D-BLK	SSP-110-SW4D-SIL



Aluminium chequer plate for TDCi Puma bonnet

3mm thick high-quality 5 bar pattern aluminium chequer Plate Kit for TDCi Puma bonnets

- Black powder coated or anodized silver finish
- Includes fitting kit
- DIY or fitting service is available

Application 90, 110, 130 Puma	SKU
Black	PUMA-BON-CP-1P-BLK
Anodised	PUMA-BON-CP-1P-ANOD



Two piece aluminium chequer plate for TDCi Puma bonnet

3mm thick high-quality 5 bar pattern aluminium chequer plate for TDCi Puma bonnet. Supplied as two-piece kit

- Black powder coated or anodized silver finish
- Includes fittings kit

Application 90, 110, 130 Puma	SKU
Black	PUMA-BON-CP-2P-BLK
Anodised	PUMA-BON-CP-2P-ANOD

## Aluminium chequer plate for wing tops

- Black powder coated or anodized silver finish, 3mm thick high quality 5 bar pattern aluminium chequer plate
- Includes fitting kit.
- Sold in pairs - Nearside and offside
- DIY or fitting service is available

Application 90, 110, 130 Puma	SKU
Wing tops black	PUMA-WT-CP-BLK
Wing tops anodised	PUMA-WT-CP-ANOD

Application 90, 110, 130, TD5, 200/300Tdi	SKU
Wing top aerial right side UK black	TD5-WT-CP-RH-BLK
Wing top aerial left side USA black	TD5-WT-CP-LH-BLK
Wing top aerial right side UK anodised	TD5-WT-CP-RH-ANOD
Wing top aerial left side USA anodised	TD5-WT-CP-LH-ANOD

## Steps: NAS Style, Wheel and Folding



### NAS rear step for 90 and 110

Our Land Rover Defender NAS rear step is made out of zinc plated galvanised steel and finished with a black powder coat. Complete with aluminium tread plate, holes for fitting a towing hook and accommodation for electrical sockets, the NAS Rear Step is functional and aesthetic. Available with either UK or US spec tow ball/receiver.

- Fits all standard Land Rover Defender chassis
- Zinc plated and black powder coated finish
- High strength construction
- DIY or fitting service is available
- Includes fitting kit

Application	SKU
90 UK	NAS-STEP-90-UK
110 UK	NAS-STEP-110-UK
90 USA	NAS-STEP-90-USA
110 USA	NAS-STEP-110-USA



### Twin rear step for Land Rover Defender

Heavy duty, easy to fit and very practical, our twin rear step for the Land Rover Defender is built to last.

- Available in a slatted style or chequer plate patterns
- Heavy duty steel construction
- Zinc plated and black powder coated finish
- DIY or fitting service is available



Application 90 & 110	SKU
Slatted	MASAI-OM172B
Chequer plate	MASAI-OM172B-CHO



### Side folding step for Land Rover Defender

- Folds down and up for convenience
- Spring mechanism
- Rubber covered foot plate
- High quality powder coated finish
- Laser cut to minimise welding points and provide a superior finish
- Boxed with fitting kit
- For 90 or 110, may fit other models too

Application	SKU
90, 110	STC7631



### Rear folding step for Defender

- Folds down and up for convenience
- Spring mechanism
- Rubber covered foot plate
- High quality powder coated finish
- Laser cut to minimise welding points and provide a superior finish
- Boxed with fitting kit
- For 90 or 110, may fit other models too

Application	SKU
90, 110	STC7632



### Wheel step - fits most 4x4 vehicles and tyres

Designed for gaining easier access to your roof rack, or the engine, and you can also use Masai's wheel step as a viewing platform and a seat.

- High strength steel construction
- Non-slip chequer plate
- 3-stage height adjustment
- Convenient folding design
- Fits most 4x4 tyres
- Zinc undercoat with silver painted finish
- Use as roof access, viewing platform or seat
- Maximum weight 150kg

Application	SKU
4x4	OM7633

# Steps and Tree / Rock Sliders



## Tree / rock sliders for 90 and 110

Here at Masai, we design and manufacture high quality tree sliders for the Land Rover Defender 90 and 110.

Looking fantastic on any model of Defender, Masai tree / rock sliders help protect the lower sides of your Land Rover when tackling difficult terrain.

- Available in Black/Silver or Black/Orange
- Zinc plated heavy duty steel construction
- Black powder coated finish
- Includes fitting kit and instructions

We also have a paint service available. Please contact us for details.

Application	SKU
90 black and orange	MASAI-TS90-BLK-ORA
90 black and silver	MASAI-TS90-BLK-SIL
110 black and orange	MASAI-TS110-BLK-ORA
110 black and silver	MASAI-TS110-BLK-SIL



## "Fire and Ice" style tubular side steps for 90 and 110

Our premium "Fire and Ice" style tubular side steps for 90 and 110 (1983-2016) are made to the same quality and specifications as our tree sliders; heavy duty steel with zinc plated and powder coated to prevent rust and corrosion.

- Heavy duty steel and Zinc, galvanised for long life protection
- Attractive "Masai" branded tread plate, made of rubber and brushed aluminium
- Supplied in pairs with rubber insert
- Orange, black or silver coloured plate
- Attaches with bolts. No drilling is required
- Clamps to the chassis outriggers
- Includes fitting kit and instructions

Application	SKU
90 Orange	FITSS-90-ORA
90 Black	FITSS-90-BLK
90 Silver	FITSS-90-SIL
110 2 door Orange	FITSS-110-2D-ORA
110 2 door Black	FITSS-110-2D-BLK
110 2 door Silver	FITSS-110-2D-SIL
110 4 door Orange	FITSS-110-4D-ORA
110 4 door Black	FITSS-110-4D-BLK
110 4 door Silver	FITSS-110-4D-SIL

Application	SKU	Spare rubber tread for side step
90 BLACK	RSSTP-MASAI-90-BLK	
90 ORANGE	RSSTP-MASAI-90-ORA	
90 SILVER	RSSTP- MASAI-90-SIL	

Application	SKU	Spare rubber tread for side step
110 BLACK	RSSTP-MASAI-110-BLK	
110 ORANGE	RSSTP-MASAI-110-ORA	
110 SILVER	RSSTP- MASAI-110-SIL	



# Masai Design and Standard Roof Access Ladders

## Masai design roof access ladder

- A high quality product designed and manufactured by the Masai engineering team. Use with NAS rear step or folding step
- Clamps to gutter and bolts to existing holes on the chassis. We also recommend drilling roof line and tub rails and further bolting on.
- Manufactured from 25 mm diameter high quality steel tubing with extra heavy duty brackets
- Zinc plated and black powder coated ensuring



## Masai design half ladder

- A high quality product designed and manufactured by the Masai engineering team. Use with NAS rear step or folding step
- Clamps to gutter and requires drilling roof line and tub rails and further bolting on.
- Manufactured from 25 mm diameter high quality steel tubing with extra heavy duty brackets
- Zinc plated and black powder coated ensuring long term rust protection



## Standard roof access ladder

- Manufactured from 25 mm diameter high quality steel tubing
- Zinc plated and black powder coated ensuring long term rust protection
- A high quality product manufactured by Masai
- Fits to existing holes on the chassis, but you will need to drill two holes at the top to

We also sell a matching lamp guard for the right hand side of the vehicle as an optional extra.

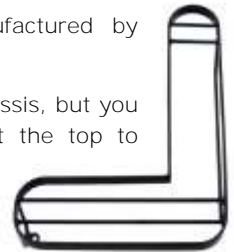

Application 90 & 110	SKU
Standard roof ladder	RAL-LRD
Masai design ladder	RAL-MAS01
Masai half ladder	RAL-MAS02

# Masai Luggage and Flat Roof Racks



## Luggage roof rack: 90 and 110

Manufactured in three lengths: 1.5m fits 90, 110 and full length of crew cab. 2.15m fits full length of 90, also fits 110. 2.8m fits full length of 110 station wagon and hard top. Masai Defender roof racks are easy to assemble using supplied fitting instructions.

- The 1.5m also fits the Discovery 1 and 2 with addition of height extension kit
- The frame rail is 120mm high and 1370mm wide
- Overall height including brackets from the gutter line is 360mm (Disco 1 & 2 is higher)
- Zinc plated steel with powder coated finish

This particular rack is not suitable for folding roof tents as the side rail is too high

Size	SKU
1.5m	LUGRR120-1.5
2.15m	LUGRR120-2.15
2.8m	LUGRR120-2.8



## Flat roof rack: 90 and 110

Manufactured in three lengths: 1.5m fits 90, 110 and full length of crew cab. 2.15m fits full length of 90, also fits 110. 2.8m fits full length of 110 station wagon and hard top.

- The 1.5m also fits Discovery 1 and 2 with addition of height extension kit
- The 2.8m is only suitable for Land Rover Defender 110
- The frame rail is 45mm high, and 1370mm wide
- Overall height including brackets from the gutter line is 285mm (Disco 1 and 2 is higher)
- Suitable for folding tents. DIY assembly
- Zinc plated steel with powder coated finish

Size	SKU
1.5m	FLRR45-1.5
2.15m	FLRR45-2.15
2.8m	FLRR45-2.8

# Masai Tubular Roof Racks for 90 and 110



SKU: 90	110	110 Crew cab
TRR-90-2.15	TRR-110-2.8	TRR-110-1.5

Available lengths: 1.5m for crew cab 4 door, 2.15m for 90 station wagon and hard top and 2.8m for 110 station wagon and hard top.

- Zinc plated and powder coated steel
- Overall height including brackets from the gutter line is 300mm. Removable bars for sunroof access
- The 2.8m is only suitable for Land Rover Defender 110 station wagon and hard top



# Masai Aluminium Luggage and Flat Roof Racks



We are proud to have designed and developed a wide range of robust roof racks manufactured from high grade, light-weight, aluminium profiles using stainless steel fittings. Our flat multi-purpose roof rack is suitable for a variety of applications such as expedition roof tents. Having two side bars our luggage roof racks are available with side bars all around or with single or double open ends to make loading easier. Masai aluminium roof racks are a practical and stylish addition to your land rover.



Manufactured in three lengths:

- 1.5m fits 90, 110 and full length of crew cab
- 2.15m fits full length of 90, also fits 110
- 2.8m fits full length of 110 station wagon and hard top
- The 1.5m also fits the Discovery 1 and 2 with height extension kit. Special order only



Size	SKU	Flat roof rack
1.5m	ALU-FLRR1.5	
2.15m	ALU-FLRR2.15	
2.8m	ALU-FLRR2.8	

Right images show luggage rack with two side bars and left images show flat roof rack.

1.5m roof racks are supplied with 4 support legs,

Size	SKU	Luggage roof rack
1.5m	ALU-LUGRR1.5	
2.15m	ALU-LUGRR2.15	
2.8m	ALU-LUGRR2.8	

# Masai Aluminium Open Ended and "Curve" Luggage Roof Racks



To assist in loading your Masai aluminium luggage roof rack we have the option of a single or double open ended design. The single open end can be positioned facing either to the rear or front of the vehicle. Our **unique "curve" luggage design** has two bars all around that follow the profile of your defender.

Manufactured from high quality extruded Aluminium profiles and using stainless steel fittings, our roof



Manufactured in three lengths:

- 1.5m fits 90, 110 and full length of crew cab
- 2.15m fits full length of 90, also fits 110
- 2.8m fits full length of 110 station wagon and hard top
- The 1.5m and 2.15 fit the Discovery 1 and 2 with height extension kit. Special order only

Central images shows curved luggage rack with two side bars and outer images show single open ended rack.

1.5m roof racks are supplied with 4 support legs, 2.15m with 6 legs and 2.8m with 8 legs. Additional legs are available as extra.

Size	SKU Single open end
1.5m	ALU-LUGRR1.5-OPEN
2.15m	ALU-LUGRR2.15-OPEN
2.8m	ALU-LUGRR2.8-OPEN

Size	SKU Curved
1.5m	ALU-LUGRR1.5-CURV
2.15m	ALU-LUGRR2.15-CURV
2.8m	ALU-LUGRR2.8-CURV

Size	SKU Double open ended
1.5m	ALU-LUGRR1.5-DOPEN
2.15m	ALU-LUGRR2.15-DOPEN
2.8m	ALU-LUGRR2.8-DOPEN

# Winch Bumpers and A-Bars



## Tubular winch bumper for 90 and 110

We design our winch bumpers to fit as many types of Land Rover Defender and winch as possible. All our winch bumpers are a zinc plated and powder coated steel for durability and life long rust protection.

- Fits most winches
- Fits Land Rover Defender 90 and 110
- Zinc plated and powder coated steel
- Easy to re-paint if scratched
- Winch assembly holes are 120mm x 260mm apart
- Extension kit required for models with aircon

Front Plate Colour	SKU
Orange	M-TWB-01-ORANGE
Black	M-TWB-01-BLACK
Silver	M-TWB-01-SILVER



## Winch bumper for 90 and 110

- Front bumper, fits most winches
- Winch assembly holes are 120mm x 260mm apart
- Zinc plated and powder coated steel
- Black and silver standard finish. Can be re-painted if scratched or to your colour choice

Version	SKU
90, 110	MASAI-WB

## Winch bumper with LED lights

Our steel winch bumper features pre-cut fittings for our LED light range, featured at the back of this catalogue.

- Suitable for Land Rover Defender 90 and 110 models
- Fits on top of the existing bumper fixing points
- Features LED light fittings
- High quality steel
- Zinc plated for rust free life and black powder coated finish.
- Two versions available for vehicles with and without air-conditioning

Version	SKU
Air-con	MAS-WB-LED-65-AC
No air-con	MAS-WB-LED-65-NON-AC



### Tubular LED light bumper

Similar to our tubular winch bumper but without facility to attach a winch. Offset number plate is required. Includes two LED daytime running lights.

- Fits 90 and 110
- Zinc plated steel for maximum protection
- Black powder coated finish
- Includes two LED daytime running lights
- Can be painted

Application	SKU
90, 110	MASAI-TBUMP-LED



### Nudge bar (A-bar/A-frame) for off-roading

Our tubular steel nudge bar (A-bar/A-frame) for off-roading use.

- Suitable for Land Rover Defender 90 and 110 models without air conditioning
- Fits on top of the existing bumper fixing points.
- **High quality tubular steel 2.5" (60 mm) diameter.**
- Zinc plated for rust free life and black powder coated finish.
- Dimensions are 850 x 590 x 140mm
- For off-road use only

Application	SKU
90, 110	MAS-37-N-BAR



### Bumper light bar

Our tubular steel light bar designed to fit on most Land Rover Defender bumpers. Ideal for our winch bumper with LED lights.

- Suitable for Land Rover Defender vehicles with or without air conditioning
- Fits on top of the existing bumper fixing points
- Zinc plated for rust free life and black powder coated finish.
- Light bar includes fixing points for two lights
- Lights not included

Application	SKU
90, 110	MAS-BLB

# Snorkels



Snorkel kit for 90 and 110  
Raised air intake, for roll cage

A snorkel, also known as a raised air intake, protects engines from the damaging effects of water, dust and sand encountered in touring and off-roading.

- Cyclonic pre-cleaner - Integrated fins create a pre-cleaning centrifugal effect to reduce the intake of sand/dust particles.
- 70mm diameter tube
- Zinc plated steel tube and mushroom top painted in gloss black
- Complete with fitting kit
- Paint service available

Application	SKU
200TDI ROLL CAGE VERSION	STC50265RC-LH
300TDI/TD5/TDCI PUMA FOR ROLL CAGE	STC50265RC-RH



Snorkel kit for 90 and 110

A snorkel, also known as a raised air intake, protects engines from the damaging effects of water, dust and sand encountered in touring and off-roading.

- Cyclonic pre-cleaner - Integrated fins create a pre-cleaning centrifugal effect to reduce the intake of sand/dust particles.
- 70mm diameter tube
- Zinc plated steel tube and mushroom top painted in gloss black
- Complete with fitting kit
- Paint service available
- Standard model

Application	SKU
200TDI STANDARD	STC50265LH
300TDI/TD5/TDCI PUMA STANDARD	STC50265RH



Snorkel air intake hose for Land Rover Defender 90 and 110

For 90, 110, 200Tdi, 300Tdi, TD5, Puma

- Genuine hose for kit STC50265
- 300mm Long
- ID 70mm, OD 79mm
- Rubber reinforced with metal wire

Application	SKU
90, 110	STC50265-H



# Air Intakes



## “Style 3” Air intake cover for Land Rover Defender

Protects against heavy rain, snow and dust.

- Made of fiberglass and can be painted
- Unique special Masai design
- Metallic silver or satin black, please see website for special all black and black and orange versions
- Custom paint service available

Application	SKU
90, 110 Air intake on the left side Right hand drive vehicles (UK) Black	AIC-03RHD-BLK
90, 110 Air intake on the right side Left hand drive vehicles (USA) Black	AIC-03LHD-BLK
90, 110 Air intake on the left side Right hand drive vehicles (UK) Silver	AIC-03RHD-SIL
90, 110 Air intake on the right side Left hand drive vehicles (USA) Silver	AIC-03LHD-SIL



## “Style 2” Air intake cover for Land Rover Defender

An air intake cover protects against heavy rain, snow and dust.

- Made of fiberglass and can be painted
- Metallic silver or satin black painted
- Custom paint service available
- Available for RH and LH drive vehicles

Application	SKU
90, 110 Air intake on the left side Right hand drive vehicles (UK) Black	AIC-02RHD-BLK
90, 110 Air intake on the right side Left hand drive vehicles (USA) Black	AIC-02LHD-BLK
90, 110 Air intake on the left side Right hand drive vehicles (UK) Silver	AIC-02RHD-SIL
90, 110 Air intake on the right side Left hand drive vehicles (USA) Silver	AIC-02LHD-SIL



## “Style 1” Air intake cover for Land Rover Defender

An air intake cover protects against heavy rain, snow and dust.

- Standard sized fitting
- Made of fiberglass with a gelcoat
- Simple DIY fitting
- LH or RH drive option
- Custom paint service available

Application	SKU
90, 110 Air intake on the left side Right hand drive vehicles (UK)	AIC-01RHD
90, 110 Air intake on the right side Left hand drive vehicles (USA)	AIC-01LHD

# Guards



## Steering and sump guard for Land Rover Defender (6mm thick steel)

A steering and sump guard protects from rock, tree, root and stump damage. Our steering and sump guard is designed to fit standard Land Rover Defenders. Made from heavy duty 6mm thick mild steel with zinc plating, the Masai steering and sump guard is built to last.

Shackles with pins (to go in the towing eyelets) are optional extras. We supply our steering and sump guard in durable zinc finish which can be easily painted prior to fitting. We also offer a high quality painting service.

- Fits all standard Land Rover Defenders, 90, 110 and 130.
- Heavy duty 6mm thick mild steel with zinc plating
- Very easy to fit, it bolts onto the chassis
- Stainless steel fittings kit

Application	SKU
90, 110, 130	LRD-SG



## Heavy duty differential guard for Land Rover axles

**Land Rover differential guard, designed to protect the vehicle's differential from damage.**

- Fits all standard Land Rover axles front or rear and all Defenders 90, 110, 130, series II/III, Discovery, Range Rover Classic.
- Heavy duty 5mm thick high tensile carbon steel with high quality zinc galvanised plating
- High strength construction with superior clean welding laser-cut
- Includes two 8 mm x 70 mm cylindrical Allen key bolts with heavy gauge zinc plating and two nyloc nuts
- Very easy to fit without any drilling

Application	SKU
90, 110, 130, series II/III, Discovery, Range Rover Classic.	OM121Z

Lighting







A wide range of LED and HID lights from a long established UK company

There's been a growing demand over recent years for vehicle lighting which gives greater luminosity yet consumes less power and is far longer lasting than conventional filament bulbs. LED lights very much meet that need and to meet this demand we have sourced high quality LED and HID vehicle lights from around the world and will be continually updating our range to keep pace with the latest innovations.



### LED and HID lights

We have a wide range of LED and HID vehicle lights in various wattages, designs and sizes—IP65 and IP67 compliant. We supply and manufacture headlights, work lights, light bars, brake lights and even LED side light kits specifically for Land Rover Defenders.



# LED Work and Driving Lights



15 or 18 Watts 6" light bar

- Can adjust vertical angle 120 degrees, and full rotation
- Power: 15 or 18 Watts, Epistar LEDs are 3W each
- Operating Volts: 10-30v DC
- Beam: Flood beam
- Lumens output: Approx. 1,350 lumens
- Colour temperature: 6,000K
- Waterproof spec: IP67
- **6" wide die cast aluminium housing, stainless steel bracket**
- Approx. 20,000 hours life time
- ROHS compliance (2011/65/EU)

Application	SKU
15 watt	5.7-REC-5-LED-WL-FB-15W-6152
18 watt	6-REC-6-LED-WL-FB-18W-6183



18 Watts rectangular work lamp, flood beam, 6 Epistar LEDs

- Can adjust angles
- Width: 4.3 inches
- Size: 110 x 60 x 55mm (excluding bracket)
- Power: Total 18 Watts, Epistar LEDs are 3W each
- Operating Volts: 10-30v DC
- Lumens output: Approx. 1,350 lumens
- Colour temperature: 6,000K
- Waterproof spec: IP67
- Material: die cast aluminium housing, stainless steel bracket
- ROHS compliance (2011/65/EU)
- Operation temperature -40°C to 60°C

Application	SKU
All	4.5-REC-6-LED-WL-18W-6182



18 Watts 4" round work light, 6 Epistar LEDs

- Can adjust vertical angle and full rotation
- Power: 18 Watts, Epistar LEDs are 3W each
- Operating Volts: 10-30v DC
- Beam: Flood beam
- Lumens output: Approx. 1,800 lumens
- Colour temperature: 6,000K
- Waterproof spec: IP67
- Material: die cast aluminium housing, stainless steel bracket
- Approx. 30,000 hours life time
- ROHS compliance (2011/65/EU)
- Size: 115mm x 115mm x 85mm
- Operation temperature -40°C to 60°C

Application	SKU
All	4-ROU-6-LED-WL-18W-6185



18 Watts 6" rectangular work light, 6 Epistar LEDs, flood beam

- Can adjust vertical angle and full rotation
- Power: 18 Watts, Epistar LEDs are 3W each
- Lumens output: Approx. 1350 lumens
- Operating Volts: 10-30v DC
- Size: 150mm x 60mm x 100mm
- Beam: Flood beam
- Lens: Polycarbonate
- Waterproof spec: IP67
- Material: die cast aluminium housing, stainless steel bracket
- Approx. 30,000 hours life time
- ROHS compliance (2011/65/EU)
- Operation temperature -40°C to 60°C

Application	SKU
All	6-REC-6-LED-WL-18W-6188



20 Watts 5" rectangular single bar CREE LED vehicle light

- Power: 20 Watts, LEDs are 10W each
- Operating Volts: 10-30v DC
- Lumens output: Approx. 1,800 lumens
- Angle: Can adjust angle
- Size: 115x60x80mm
- Colour temperature: 5k-6k
- Operation temperature -40°C to 60°C
- Waterproof spec: IP67
- Material: die cast aluminium housing, stainless steel bracket
- Housing colour: Black
- Lens: Toughened Glass

Application	SKU
All	5-REC-2-LED-FB-20W-6012



24 Watts 4" rectangular work light, 8 Epistar LEDs

- Can adjust vertical angle and full rotation
- Power: 24 Watts, Epistar LEDs are 3W each
- Operating Volts: 10-30v DC
- Beam: Flood beam
- Lumens output: Approx. 1,850 lumens
- Colour temperature: 6,000K
- Waterproof spec: IP67
- Material: die cast aluminium housing, stainless steel bracket
- Lens: PMMA
- Approx. 30,000 hours life time
- ROHS compliance (2011/65/EU)
- Size: 140mm x 55mm x 70mm
- Operation temperature -40°C to 60°C

Application	SKU
All	4-REC-8-LED-WL-24W-6247



24 Watts 7.5" rectangular work light, 24 Epistar LEDs

- Can adjust vertical angle and full rotation
- Power: 24 Watts, Epistar LEDs are 1W each
- Lumens output: Approx. 2900 lumens
- Operating Volts: 10-30v DC
- Size: 200mm x 40mm x 120mm
- Beam: Flood beam 90 degrees
- Lens: PMMA
- Colour temperature: 6,000K
- Waterproof spec: IP67
- Material: die cast aluminium housing, stainless steel bracket
- Approx. 30,000 hours life time
- ROHS compliance (2011/65/EU)
- Operation temperature -40°C to 60°C

Application	SKU
All	7.5-REC-24-LED-WL-24W-6245



27 Watts 4" round work light, 9 Epistar LEDs

- Angle: Can adjust angles
- Width: 4.3 inches
- Size: 110 x 60 x 55mm (excluding bracket)
- Power: Total 27 Watts, LEDs are 3W each
- Operating Volts: 10-30v DC
- Lumens output: Approx. 2,150 lumens
- Colour temperature: 6,000K
- Waterproof spec: IP67
- Material: die cast aluminium housing, stainless steel bracket
- Lens: PMMA Lens
- ROHS compliance (2011/65/EU)
- Approx. 30,000 hours life time
- Operation temperature -40°C to 60°C

Application	SKU
All	4-ROU-9-LED-WL-27W-6272-FB



36 Watts 6.5" oval work light, 12 CREE LEDs

- Can adjust vertical angle and full rotation
- Power: 36 Watts, CREE LEDs are 3W each
- Lumens output: Approx. 3400 lumens
- Operating Volts: 10-30v DC
- Size: 175mm x 77mm x 157mm
- Beam: Flood or spot beam
- Lens: Polycarbonate
- Colour temperature: 6,000K
- Waterproof spec: IP67
- Material: die cast aluminium housing, stainless steel bracket
- Approx. 30,000 hours life time
- ROHS compliance (2011/65/EU)

Type	SKU
Spot	6.5-OVA-12-LED-WL-36W-6365-SB
Flood	6.5-OVA-12-LED-WL-36W-6365-FB



Pair of 36 Watt 5.5" round headlights / driving lights, 12 Epistar LEDs

- Rear Mounting Bracket
- Power: 36 Watts, Epistar LEDs are 3W each
- Operating Volts: 10-30v DC
- Beam: Spot beam
- Lumens output: Approx. 2,600 lumens
- Colour temperature: 6,000K
- Waterproof spec: IP67
- Material: die cast aluminium housing, stainless steel bracket
- Lens: Polycarbonate
- Approx. 30,000 hours life time
- ROHS compliance (2011/65/EU)
- Operation temperature -40°C to 60°C

Application	SKU
All	5.5-ROU-12-LED-HL-36W-6054



40 Watts 8" rectangular single Bar vehicle work light, 4 CREE LEDs

- Power: 40 Watts, LEDs are 10W each
- Operating Volts: 10-30v DC
- Lumens output: Approx. 3,600 lumens
- Angle: Can adjust angle
- Beam: Flood Light and spot light combo
- Size: 200x80x60mm
- Colour temperature: 5k-6k
- Operation temperature -40°C to 60°C
- Waterproof spec: IP67
- Material: die cast aluminium housing, stainless steel bracket
- Lens: Toughened Glass

Application	SKU
All	8-REC-4-LED-40W-COM-6012



40 Watts 5" rectangular work light, 4 CREE LEDs, flood beam

- Can adjust vertical angle and full rotation
- Power: 40 Watts, LEDs are 10W each
- Lumens output: Approx. 3500 lumens
- Operating Volts: 10-30v DC
- Size: 127mm x 90mm x 160mm
- Beam: Flood beam
- Lens: Toughened glass
- Colour temperature: 6,000K
- Waterproof spec: IP67
- Material: die cast aluminium housing, stainless steel bracket
- Approx. 30,000 hours life time
- ROHS compliance (2011/65/EU)
- Operation temperature -40°C to 60°C

Application	SKU
All	5-REC-4-LED-40W-FB-6402





42 Watts 4.5" round work light,  
14 Epistar LEDs

- Can adjust vertical angle and full rotation
- Power: 42 Watts, Epistar LEDs are 3W each
- Lumens output: Approx. 3500 lumens
- Operating Volts: 10-30v DC
- Size: 110mm x 72mm x 110mm
- Beam: Spot beam
- Lens: Polycarbonate
- Colour temperature: 6,000K
- Waterproof spec: IP67
- Material: die cast aluminium housing, stainless steel bracket
- Approx. 30,000 hours life time
- ROHS compliance (2011/65/EU)
- Operation temperature -40°C to 60°C

Application	SKU
All	4.5-ROU-14-LED-WL-42W-6421



45 Watts 7" rectangular work  
light

- Angle: Can adjust angles
- **Size: 7" wide**
- Power: 45 Watts, LEDs are 3W each
- Operating Volts: 10-30v DC
- Lumens output: Approx. 3,200 lumens
- Colour temperature: 6,000K
- Waterproof spec: IP67
- Material: die cast aluminium housing, stainless steel bracket
- Lens: PMMA Lens
- ROHS compliance (2011/65/EU)
- Approx. 30,000 hours life time
- Operation temperature -40°C to 60°C

Application	SKU
All	7-REC-15-LED-WL-45W-SB-6053



80 Watts 8" rectangular CREE  
LED spot beam light

- Can adjust vertical angle and full rotation
- Power: 80 Watts, CREE LEDs are 10W each
- Lumens output: Approx. 6,500 lumens
- Operating Volts: 10-30v DC
- Beam: Spot beam
- Lens: Polycarbonate
- Colour temperature: 6,000K
- Waterproof spec: IP67
- Material: die cast aluminium housing, stainless steel bracket
- Approx. 30,000 hours life time
- ROHS compliance (2011/65/EU)
- Operation temperature -40°C to 60°C

Application	SKU
All	8-REC-8-LED-VWLB-80W-6027



Pair of 45 Watt 5.5" round headlights, 9 CREE LEDs

- Can adjust angle 160 degrees
- Power: 45 Watts each, CREE LEDs are 5W each
- Operating Volts: 10-60v DC
- Beam: Spot beam
- Lumens output: Approx. 3,800 lumens
- Colour temperature: 6,000K
- Waterproof spec: IP67
- Material: die cast aluminium housing, stainless steel bracket
- Approx. 30,000 hours life time
- ROHS compliance (2011/65/EU)
- Size: 140mm x 140mm x 169mm
- Operation temperature -40°C to 60°C

Application	SKU
All	5.5-ROU-9-LED-HL-45W-6051



45 Watts 6" rectangular work light, 15 LEDs, flood beam

- Power: 45 Watts, LEDs are 3W each
- Operating Volts: 10-30v DC
- Lumens output: Approx. 3,900 lumens
- Angle: Can adjust angle
- Beam: Flood Light
- Colour temperature: 6k
- Operation temperature -40°C to 60°C
- Waterproof spec: IP67
- Material: die cast aluminium housing, stainless steel bracket
- Housing colour: Black
- Lens: Toughened Glass

Application	SKU
All	6-REC-15-LED-WL-45W-6451-FB



50 Watts 5" rectangular work light, 5 CREE LEDs

- Can adjust vertical angle and full rotation
- Power: 50 Watts, CREE LEDs are 10W each
- Lumens output: Approx. 3800 lumens
- Operating Volts: 10-30v DC
- Size: 145mm x 96mm x 80mm
- Beam: Flood beam
- Lens: Polycarbonate
- Colour temperature: 6,000K
- Waterproof spec: IP67
- Material: die cast aluminium housing, stainless steel bracket
- Approx. 30,000 hours life time
- ROHS compliance (2011/65/EU)
- Operation temperature -40°C to 60°C

Application	SKU
All	5-REC-5-LED-WL-50W-6501-FB



Pair of 51 Watts each, 7" round headlights, 17 Epistar LED

- Adjustable angle
- Power: 51 Watts, Epistar LEDs are 3W each
- Operating Volts: 10-30v DC
- Beam: Flood beam
- Lumens output: Approx. 3,700 lumens
- Colour temperature: 6,000K
- Size: 160mm x 86mm x 202mm
- Material: die cast aluminium housing, stainless steel bracket - IP67
- Lens: Polycarbonate
- Approx. 30,000 hours life time
- Operation temperature -40°C to 60°C
- ROHS compliance (2011/65/EU)

Colour	SKU
Red	7-ROU-17-LED-HL-51W-RED-6511
Black	7-ROU-17-LED-HL-51W-BLACK-6511



Pair of round headlight, 12 Cree LEDs, 7" Lens, 60 Watts each

- Adjustable angle: 160 degrees
- Power: 60 Watts, Cree LEDs are 5W each
- Operating Volts: 10-60v DC
- Beam: Spot beam – Polycarbonate lens
- Lumens output: Approx. 5,100 lumens
- Colour temperature: 6,000K
- Waterproof spec: IP67
- Material: die cast aluminium housing, stainless steel bracket
- Approx. 30,000 hours life time
- ROHS compliance (2011/65/EU)
- Size: 180mm x 180mm x 207mm
- Operation temperature -40°C to 60°C

Application	SKU
All	7-ROU-12-LED-HL-60W-6051



Pair of 70 Watts each, 7000 Lumens each, 6" round headlights, 7 Cree LEDs

- Can adjust angle
- Power: 70 Watts each, Cree LEDs are 10W each
- Operating Volts: 10-60v DC
- Beam: Combo beam - PMMA lens
- Lumens output: Approx. 7,000 lumens each
- Colour temperature: 6,000K
- Waterproof spec: IP67
- Material: Black die cast aluminium housing, stainless steel bracket
- Approx. 30,000 hours life time
- ROHS compliance (2011/65/EU)
- Size: 155mm x 155mm x 102mm
- Operation temperature -40°C to 60°C

Application	SKU
All	6-ROU-7-LED-HL-70W -6701

# LED Headlights

## Pair of 7" powerful CREE LED headlights

Sealed dip and main beam LED headlights. 7" lights with option outer retaining ring. Perfect for off-road vehicles such as Land Rovers, motorcycles, heavy duty trucks, military applications etc. Available in left and right hand drive traffic versions. Beam appears as pure white light, Lower power than Halogen and Xenon alternatives. Up to 50x longer life offering the same forward visibility without harsh glare. Die cast aluminium housing. Polycarbonate lenses offering superior impact protection against road debris and other hazards. H4, 3-blade connector. DOT and E Marked.

- Mount: compatible with PAR56 -7 inch diameter headlamps
- Right hand and left hand drive versions
- Optional Outer Retaining Ring made of painted steel
- Parabolic Aluminised Reflector
- **Highly durable and economical CREE LED's**
- Low Beam - 2800 Lumens at 30 watts
- High Beam - 4450 Lumens at 48 watts
- Row Lumen output is 5600LM, Effective 3640LM
- Step-less thermal management
- Dipped and Main beam functions
- Standard H4 socket, and H4 to H13 converter
- Multi-Volt - Both 12V And 24V Systems
- Colour temperature 6000 to 6500k



Traffic hand	SKU
Right hand drive (UK)	7-ROU-6-LED-HL-48W-RH
Left hand drive (USA)	7-ROU-6-LED-HL-48W-LH
Retaining ring	MASAI-7INCH-ORR

# LED Headlights

## Pair of 7" ECE LED headlights

Sealed beam LED headlights with dipped beam and main beam modules. Perfect for off-road vehicles, motorcycles, heavy duty trucks, military applications and more. With the appearance of a pure white light, LED headlights run at lower power than Halogen and Xenon alternatives – ensuring up to 50x longer life – and offer the same forward visibility without the harsh glare. Our LED headlights have die cast aluminium housings, polycarbonate lenses and use a 3-Blade connector. Available in left and right hand drive traffic versions.

- ECE and ROHS Compliant
- LED sealed beam technology with Polycarbonate Lens And Sealed Electronics

Material:

- Hard-coated polycarbonate lens
- eCoat aluminum housing and internal

Structure:

- Metalized reflector » 1.3mm CSA / 16 gauge wire

Light source:

- 2 LED arrays power:
- Multi-volt (9V-33V) design works with both 12V And 24V systems

Headlamp:

- 1.3A (Dipped/Passing) @ 13.2V
- 2.3A (Main/Driving) @ 13.2V
- 0.6A (Dipped/Passing) @ 26.4V
- 1.1A (Main/Driving) @ 26.4V
- Position lamp 0.03A @ 13.2V, 0.03A @ 26.4V
- Operating temperature: **-40°C To 50°C**
- Overvoltage protection To 600V
- Retaining ring code: MASAI-7INCH-ORR
- 1300 Lumens each



Traffic hand	SKU
Right hand drive UK	M-TL-LED-HL-ROU-RH
Left hand drive USA	M-TL-LED-HL-ROU-LH
Retaining ring	MASAI-7INCH-ORR

# HID Xenon Off-Road Lights



Vehicle lighting wiring kit.

With relay, fuse and switch for our HID and LED lights

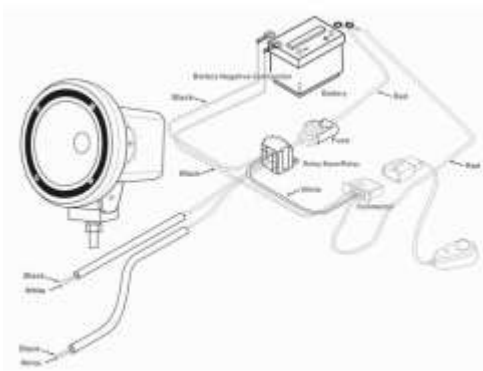

Application	SKU
HID & LED	WIRING-HID



Pair of 55 Watt, 7" HID Xenon Spot beam off-road lights

- Adjustable angle: Flood or Spot beam
- Lumens output: Approx. 3,200 lumen each
- Operating volts: 9V-32V DC
- Power: 55w each
- Wiring kit included with fuse, switch and relay
- HID Bulb: H3 - Off road use
- Lifespan: Approx. 3000 operating hours
- Colour temperature: 6,000K
- Cover: includes detachable clear polycarbonate lens cover
- Size: 205mm wide x 150mm deep x 215mm high
- Working temperature -40c to 80c

Application	SKU
Flood beam	7-HID-55W-3700-FB
Spot beam	7-HID-55W-3700-SB



Pair of 55 Watt, 4" HID Xenon off-road driving Lights

- Can adjust angle
- Lumens output: Approx. 3,200 lumen each
- Operating volts: 9V-32V DC
- Power: 55w each
- Wiring kit included with fuse, switch and relay
- HID Bulb: H3- Off road use
- Lifespan: Approx. 3000 operating hours
- Colour temperature: 6,000K
- Cover: includes detachable clear polycarbonate lens cover
- Size: 205mm wide x 150mm deep x 215mm high
- Working temperature -40c to 80c

Application	SKU
Flood beam	4-HID-55W-DL-3410-FB
Spot beam	4-HID-55W-DL-3410-SB



Pair of 55 Watt, 9" HID Xenon off-road driving lights

- Can adjust angle
- Power: 55w each
- Lumens output: Approx. 3,200 lumen each
- Operating volts: 9V-32V DC
- Wiring kit included with fuse, switch and relay
- Size: 10" wide with 9" lens
- HID Bulb : H3-Off road use
- Lens: Toughened glass
- Lifespan: Approx. 3,000 operating hours
- Colour temperature: 6,000K
- Size: 250mm wide x 180mm deep x 270mm

Type	SKU
Flood beam	9-HID-55W-3900-FB
Spot beam	9-HID-55W-3900-SB



Pair of 70 Watt, 9" HID Xenon off-road driving lights

- Can adjust angle
- Power: 70w each
- Lumens output: Approx. 4,100 lumen each
- Operating volts: 9V-32V DC
- Wiring kit included with fuse, switch and relay
- Size: 10" wide with 9" lens
- HID Bulb : H3—Off road use
- Lens: Toughened glass
- Lifespan: Approx. 3,000 operating hours
- Colour temperature: 6,000K
- Size: 250mm wide x 180mm deep x 270mm
- Working temperature -40c to 80c

Type	SKU
Flood beam	9-HID-70W-3900-FB
Spot beam	9-HID-70W-3900-SB



35 and 55 Watts 6.5" Xenon HID work spot light with handle

- Can adjust vertical angle and full rotation
- Power: 35 & 55 Watts, Xenon HID, H3 bulb
- Operating Volts: 9-32v DC
- Beam: Spot beam
- Colour temperature: 6,000K
- Waterproof spec: IP67
- Material: HI impact Nylon Plastic housing, stainless steel bracket
- Working temperature -45c to 80c
- Lens: Toughened Glass
- Approx. 3,000 hours life time
- ROHS compliance (2011/65/EU)
- Internal Ballast

Type	SKU
35w Flood beam	6.5-HID-WL-35W-9-32V-2015-FB
55w Flood beam	HID-WL-55W-12V-FB-2015

# LED Light Bars



CREE 260 Watt 26 LED single row light bar with optical reflector

- **Size: 43" wide**
- Power: 260w, 10w CREE LEDs
- 20500 Lumens
- Operating voltage: 10-60 Volt DC
- Colour temperature: 6000K
- Operation temperature: -40°C to 60°C
- Waterproof rate: IP67
- Beam: Spot beam
- Material: Die cast aluminium housing
- Mounting: stainless steel brackets
- Lens: Polycarbonate
- **Lifespan: Approx' 20,000 hours**

Application	SKU
All	43-REC-26-LED-VWLB-260W-6012R-SB



CREE 116 Watt light bar

- **Size: 20" wide**
- **Power: 116w, 10w CREE LED's (spot) beside 3w LED's (flood)**
- 9000 Lumens
- Operating voltage: 10-30 Volt DC
- Colour temperature: 6000K
- Operation temperature: -40°C to 60°C
- Waterproof rate: IP67
- Beam: Combo spot and flood beam
- Material: Die cast aluminium housing
- Mounting bracket: Stainless steel
- Lens: Polycarbonate
- **Lifespan: Approx' 30,000 hours**

Application	SKU
All	20-REC-20-LED-VWLB-116W-6018-COMBO



CREE 248 or 304 Watt light bar

- **42" wide for 248 watt or 50" for 304 watt**
- Power: 248 watts or 304 watts, 10w CREE LED's (spot) beside 3w LEDs (flood)
- 20000 Lumens 248w or 24000 lumens 304w
- Operating voltage: 10-30 Volt DC
- Colour temperature: 6000K
- Operation temperature: -40°C to 60°C
- Waterproof rate: IP67
- Beam: Combo spot and flood beam
- Material: Die cast aluminium housing
- Mounting bracket: Stainless steel
- Lens: Polycarbonate
- **Lifespan: Approx' 30,000 hours**

Size	SKU
248	42-REC-50-LED-VWLB-248W-6018-COMBO
304	50-REC-64-LED-VWLB-304W-6018-COMBO



# LED Light Bars and Working Lights



180 or 288 Watt light double row curved light bar

- **Two sizes: 33" and 50" wide, curved**
- Power: 180w or 288w, 3w Epistar LEDs
- 14,300 or 23,000 Lumens
- Operating voltage: 10-30 Volt DC
- Colour temperature: 6000K
- Operation temperature: -40°C to 60°C
- Waterproof rate: IP67
- Beam: Combo spot and flood beam
- Material: Die cast aluminium housing
- Mounting bracket: Stainless steel brackets
- Lens: Polycarbonate

Application	SKU
33" 180watt	33-CURV-60-LED-VWLB-180W-6029E-COMBO
50" 288watt	50-CURV-96-LED-VWLB-288W-6029E-COMBO



240 Watt double row light bar

- **Size: 42" wide**
- Power: 240w, 3w Epistar LEDs
- 15,000 Lumens
- Operating voltage: 10-30 Volt DC
- Colour temperature: 6000K
- Operation temperature: -40°C to 60°C
- Waterproof rate: IP65
- Beam: combo beam
- Material: Die cast aluminium housing
- Lens: toughened glass
- 1053mm x 90mm x 90mm

Application	SKU
All	42-REC-80-LED-VWLB-240W-6021-COMBO



120 Watt A-frame light bar

Our a-frame light bar is designed to fit on our tubular steel nudge bar (A-bar/ A-frame) (See page 31).

- **Power: 42 LED's, each 3 watt high intensity Epistar**
- 7,500 Lumens— Combo beam
- Amps: 10A at 12V, 5A at 24V
- Colour temperature: 6000K
- Operation temperature: -40°C to 60°C
- Waterproof rate: IP65
- **Lifespan: Approx' 20,000 hours**
- Lens: Toughened glass
- Housing: Powder coated die cast aluminium

Application	SKU
All	22-REC-42-LED-VWLB-120W-6021A-COMBO



120W 40 LED vehicle work light bar - combo beam, 22"

- Size: 22" wide
- Power: 120w, 40 LEDs 3w each, high intensity Epistar
- Waterproof: IP65 compliance
- Beam: Flood
- Lifespan: Approx 20,000 operating hours
- Operating volts: 10-30v DC
- Current draw: 10A at 12v, 4A at 24v
- **Lumens output: Approx' 7,500 lumens**
- Colour Temperature: 6,000K
- Material: Diecast aluminium housing and brackets

Application	SKU
All	22-REC-40-LED-VVLB-120W-6021-COMBO



144W 48 LED vehicle work light bar - flood beam, 40"

- Size: 40" wide
- Power: 144w, 48 LEDs 3w each, high intensity Epistar
- Waterproof : IP67 compliance
- Beam: Flood Beam, 60 degrees
- Lifespan: Approx. 30,000 operating hours
- Operating volts: 10-30v DC
- Lumens output: Approx. 8,000 lumens
- Colour Temperature: 6,000K
- Material: Diecast aluminium housing, black powder coated
- ROHS compliance (2011/65/EU)
- Operation temperature: -40°C to 60°C

Application	SKU
All	40-REC-48-LED-VVLB-144W-6023-FB

#### Tubular steel roof light bar

- 4 fixed position light mounting brackets
- Zinc plated and black powder coated
- Clamp-on system. No drilling required



#### Aluminium roof light bar

- 4 adjustable position light mounting brackets
- Aerodynamic black powder coated design
- Clamp-on system. No drilling required



Lights are not included as standard

Application 90, 110, 130	SKU
Tubular Steel	MLR-LB-01
Aero Aluminium	MLR-LB-02

## LED Brake, Indicator and Side Lights



### NAS style Defender LED lights kit

Our NAS style LED lights kit includes:

- 2 front side lights
- 2 front indicator lights
- 2 rear indicator lights
- 2 rear tail/brake lights
- 1 Reversing light
- 1 rear fog light
- 1 speed adjustable flasher relay
- 10 base plinths
- Screws

When ordering please specify clear or coloured lens

The LEDs inside are the correct legal colours

Application 90, 110, 130	SKU NAS style LEDs	SKU Standard LEDs
Full Set Clear Lenses	NAS-LED-LRD-SET-CLR	LED-LRD-SET-CLR
Full Set Coloured Lenses	NAS-LED-LRD-SET-COL	LED-LRD-SET-COL
Front side lights clear	NAS-FR-SL-CLR	STD-FR-SL-CLR
Front indicator clear	NAS-FR-IND-CLR	STD-FR-IND-CLR
Front indicator orange	NAS-FR-IND-ORA	STD-FR-IND-ORA
Rear indicator clear	NAS-REAR-IND-CLR	STD-REAR-IND-CLR
Rear indicator orange	NAS-REAR-IND-ORA	STD-REAR-IND-ORA
Tail/brake light clear	NAS-TAIL-BRAKE-CLR	STD-TAIL-BRAKE-CLR
Tail/brake light red	NAS-TAIL-BRAKE-RED	STD-TAIL-BRAKE-RED
Reversing light clear	NAS-REAR-REV-CLR	STD-REAR-REV-CLR
Fog light clear	NAS-FOG-CLR	STD-FOG-CLR
Fog light red	NAS-FOG-RED	STD-FOG-RED



### Standard style LED lights kit for Land Rover Defender

Our standard style LED lights kit includes:

- 2 front sidelights
- 2 front indicator lights
- 2 rear indicator lights
- 2 rear tail/brake lights
- 1 Reversing light
- 1 rear fog light
- 1 speed adjustable flasher relay
- 2 base plinths
- Screws

When ordering please specify clear or coloured lens

The LEDs inside are the correct legal colours



We also sell LED number plate lights as an optional extra to these light kits. Please inquire when placing your order. Please see page 56 for further details.

# Lamp Guards



## New style Masai Land Rover Defender front lamp guards

Our new front lamp guards for Land Rover Defender 90 and 110 are manufactured to the highest standards, with zinc plating and black powder coated finish for long life rust protection. They are full size to cover the whole of the lamp surrounds. Land Rover lamp guards are supplied in pairs, complete with fitting instructions.

- Zinc plating for long life rust protection
- Black powder coated finish
- Supplied as a pair
- DIY or fitting service is available

Application	SKU
90, 110	M-FLG-NEW-BLK
90, 110	M-FLG-NEW-SILVER



## Hinged Land Rover Defender front lamp guards

These lamp guards have a hinged design for convenience and bulb access.

- Zinc plating for long life rust protection
- Black powder coated finish
- Supplied as a pair
- Hinged design for convenience and bulb access
- Full size to cover the whole of the lamp surrounds
- DIY or fitting service is available

Application	SKU
90, 110	M-STC53161



## Pair of Land Rover Defender rear lamp guards

- Zinc plating for long life rust protection
- Black powder coated finish
- Supplied as a pair
- Hinged design for convenience and bulb access
- Full size to cover the whole of the lamp surrounds
- DIY or fitting service is available
- For use with our wheel carrier

The left hand bracket can be substituted for our

Application	SKU
90, 110 Wheel carrier version	OM8859

# Lamp Guards



## Set of Land Rover Defender rear lamp guards

- Zinc plating for long life rust protection
- Black powder coated finish
- Supplied as a pair
- Hinged design for convenience and bulb access
- Full size to cover the whole of the lamp surrounds
- DIY or fitting service is available
- Non wheel carrier version

Application	SKU
90, 110 Non wheel carrier version	OM8859-B



## NAS light guards

- Rugged plastic construction
- Designed specifically for our NAS style LED lights
- Sold individually
- Screw on to existing lights

Application	SKU
90, 110	MAS-NAS-LG

# Brake Lights, Licence Plate Light, Clips and Catches

## Rear window brake light kit

High-level brake light to fit the rear door. Original Land Rover parts, except adhesive.



Application	SKU
90, 110	DEF-BLA

## Masai rear window brake light kit

High-level brake light which can be fitted to any flat surface on the vehicle.



Application	SKU
90, 110	E-LED-BR-01



Front or middle door glass holding clips - pack of 4

Replacement glass holders/glass runners

- Genuine Land Rover part number: STC4787 (superseded AWR7092)

Application	SKU
90, 110	M-STC4787



Defender 90 and 100 replacement side rear window catches (kit)

Zinc, Magnesium and aluminium alloy strong and corrosion resistant.

Application	SKU
90, 110 Right	MTC8270
90, 110 Left	MTC8271



LED licence plate light

- Standard size direct replacement
- For land rover Defender
- Connect wiring to existing light circuit

Application	SKU
90, 110	LED-LPL-98

# HID and LED Work Lamps and Torches



55 Watt 9" portable HID Xenon spotlight with handle

- Power: 55 Watts or 35 Watts via switch
- Xenon HID, H1 bulb, Operating Volts: 12v DC
- Powered via cable and connector to cigar lighter socket. V Shaped PMMA Lens
- Housing: Hi-impact Nylon
- Wiring: powered from cigarette lighter socket.
- Beam: Spot beam, Colour temperature: 6,000K
- Operation temperature -10°C to 60°C
- IP67, 3,000 hours operating life

Application	SKU
All	9-HID-PL-55W-4700



55 Watt 8" HID Xenon torch

- Power: 55 Watts, HID H3 bulb, spot beam
- High and Low settings: 55w/35w
- Brightness: 20m Cd/m2
- Rechargeable battery is 12v, 2.5Ah
- IP66 with high impact nylon housing
- Working Temperature : -10 to +60 degrees C
- Includes shoulder strap
- Handle can be flipped up for alternative handling
- Size: 280mm x 220mm x 200mm

Application	SKU
All	8-HID-TORCH-55W-5200



50 Watts HID 3500 Lumens aluminium flashlight

- Xenon HID, High and low settings: 50w/38w. Spot beam. 3500 Lumens and 6000k colour temperature. Can be recharged via cigarette lighter or mains socket. High, 70 mins; Low, 90 mins. Lithium battery. 1.6kg aluminium housing. 6600Mah.
- Storage case size: 420mm x 200mm x 115mm

Application	SKU
All	3-HID-TORCH-50W-5001



18 or 24 Watts magnetic base LED work lamp, 4", flood beam

- **Magnetic base with approx' 3m cable and plugs into a cigarette lighter socket**
- 60° Flood beam or 30° spot — PMMA lens
- 18 Watts or 24 Watts, LEDs are 3W each
- Operating Volts: 10-30v DC
- ~ 1,350 lumens for 18w & 1,850 for 24w
- Colour temperature: 6,000K
- Waterproof spec: IP67
- ROHS compliance (2011/65/EU)
- Approx 30,000 hours life time
- Size: 116mm x 43mm x 135mm for 18w and 110mm 48mm x 135mm for 24w

Application	SKU
18 Watts Flood	4-ROU-6-LED-18W-WL-6181-FB
24 Watts Flood	4-ROU-8-LED-WL-24W-6242-FB
24 Watts Spot	4-ROU-8-LED-WL-24W-6242-SB



55 Watts remote controlled HID spot light with magnetic base

- Controlled positioning: Using a supplied remote control you can adjust the vertical angle 120 degrees and a full 360 degree horizontal rotation.
- Carry Handle adjusts approx. 90 degrees.
- Power: 55 Watts, Xenon HID, H1 bulb.
- Operating Volts: 10-30v DC.
- Powered from cigarette lighter socket.
- Size: 200mm x 237mm x 197mm
- Beam: Spot beam
- Colour temperature: 6,000K
- Harsh Environment spec: IP65
- Internal Ballast
- 9V battery required
- Operation temperature: -45°C to 80°C

Application	SKU
All	7-HID-RCL-55W-MB-2009



55 Watts 7" portable HID Xenon spot light with handle

- Easy Grip Handle.
- Power: 55 Watts, Xenon HID, H3 bulb
- Operating Volts: 12v DC
- Lens: V Shaped PMMA Lens
- Housing: ABS Plastic.
- Powered from cigarette lighter socket.
- Size: 176mm x 240mm x 250mm.
- Beam: Spot beam
- Colour temperature: 6,000K
- Operating hours: 3000
- Internal Ballast
- Harsh Environment spec: IP67
- Operation temperature: -40°C to 60°C

Application	SKU
All	7-HID-PL-55W-4702





### Shovel

- Aluminium construction, with a plastic handle and rubber mounting points
- Includes rubber mounting and securing brackets
- Can be fitted to anything with a flat surface

Application	SKU
All	M-VS-01



### Shock absorber mounting brackets kit

These special mounting brackets have been specifically designed to be used in conjunction with +5" Terrafirma Extreme long travel shock absorbers (TF122LT) which provide increased articulation and strength for off-road work.

- 6mm high tensile carbon steel, galvanised for long rust free life
- Includes 10 x 110mm zinc plated bolt sets
- Locate on original mounting points

Application	SKU
90, 110, 130, Discovery and Range Rover Classic.	M-TF519



### Land Rover Defender 90 and 110 bulkhead outrigger

- All-round laser cut to minimise welding points and provide superior finish
- Land Rover replacement parts STC8355 and STC8354
- Zinc plating for long life rust protection
- Black powder coated

Position	SKU
Nearside - Left side	STC8355
Offside - Right side	STC8354
Left and right side	STC8355/STC8354



### 30mm Wheel spacers

Wheel spacers are designed to adjust the offset of your wheels to prevent the tyres rubbing against the suspension or shock absorbers and **improve the turning circle of the vehicle.** Masai's 30mm wheel spacers are made from cast iron and aluminium. Nuts and bolts included in the kit and each kit contains 4 spacers.

Application	SKU
All	M-WS01-30



### Paper templates

We have paper templates for positioning correct cut-out of the apertures on rear side windows, quarter lights and alpine windows on a Defender hardtop 200/300Tdi, TD5 and TDCi Puma.

Template 1

Rear side windows and quarter lights

Template 2

Alpine windows

Application	SKU
Rear side windows and quarter lights	LRD-SWT
Alpine windows	LRD-ALPWT



### Rubber window seals

A pair of rubber window seals for rear quarter-light windows and alpine windows. Single windscreen seal

- A high quality Masai product
- Land Rover part codes CHB500050, CGE500450, quarter light seals and DBF500030, DBF500040, alpine window seals. Two-piece system.

Application	SKU
90, 110 Quarter light seals (pair)	DEF-RQL-WS
90, 110 Alpine rubber seals (pair)	MASAI-DBF500030-40
Defender 1985 onwards Windscreen rubber seal	MASAI-MTC5753

# Roof Awning



The Masai roof awning with compact dimensions: strong structure and low weight!

The Masai awning screws directly onto the roof rack or with our brackets to roof rails.

The casing is strong aluminium. It has a fabric canopy which is UV resistant and water resistant.

Perfect for Land Rovers, motorhomes, some caravans and van conversions.

Manual opening and closing. Designed for roof installation. Side panels are available as an extra to provide privacy.

Application	SKU
Awning	MASAI-AWNING
Side panels	MASAI-PANEL



# Masai Trucks - Specialist Vehicle Restoration and Customising Service



## At Masai we love Land Rovers....

From simply giving you our best advice to providing and fitting our unique styling and performance components to complete nut and bolt re-builds to your specification, including all mechanicals and the best quality paint finish.

At Masai we are re-imagining the classic British Land Rover. Our cars look and feel like no other cars on the market today. We pay attention to the smallest details to ensure the finished product looks amazing.

We design, manufacture, supply and globally source a wide range of Land Rover accessories including roof racks, tubular bumpers, winch bumpers, steering guards, HID lights, light guards, NAS style bumper, spare wheel carrier, LED side lights, roof ladder, scooped bonnet, side air intake, side steps, tree sliders, panoramic sliding windows, aluminium chequer plates, dark tinted side windows all of which we supply internationally from our warehouse in Lichfield UK from where we also offer a full fitting and restoration service.

Please call us to discuss your Land Rover requirements. We will be very pleased to help.





Specialists in Automotive Glass, Metal Fabrication and Cooling

Masai (Omega Automotive Ltd) are specialists in Automotive Glass, Metal Fabrication, Instrumentation, Suspension, Rubber, Cooling and Lighting. We manufacture and supply to many automotive companies around the world.

Unit 5, Eastern Park, Eastern Avenue,  
Lichfield, Staffordshire, WS13 7SY.  
United Kingdom.

Tel: +44(0)1543-254507  
Fax: +44(0)1543-418665  
Email: [info@masai.co](mailto:info@masai.co)  
[www.masai.co](http://www.masai.co)

In addition to our range of parts and accessories for the Land Rover Defender, we manufacture various types of horsebox windows, van and minibus bonded side windows, coach windscreens and some classic car parts for the E-Type Jaguar, Triumph Spitfire and Classic Mini.

Visit [www.masai.co](http://www.masai.co) for our full range of vehicle parts and accessories.



*One life... see it!*

Disclaimer: All images and part codes (SKU) used in this catalogue are for reference purposes only and specifications may change without prior notice. We reserve the right to remove any product from sale without prior notice. This catalogue is the property of Omega Automotive Limited and cannot be copied, reproduced or disseminated in any way without written permission of Omega Automotive Limited. For full terms and conditions of sale please see our website. Please check with our website for the latest information prior to ordering.



[www.masai.co](http://www.masai.co)

Masai is a registered trademark and trading name of Omega Automotive Limited.

Registered in England and Wales; Company registration number: 4436761.

VAT number: 794 887349. Registered address: Unit 5, Eastern Park, Eastern Avenue, Lichfield, Staffordshire. WS13 7SY.

2016 Edition 1